

This guide provides basic information on how to install and use the Meridian DSP320.2 loudspeaker.

Further details are provided in the comprehensive *DSP320.2 User Guide*. The loudspeaker is designed to be fitted in a Meridian RF300 Wall Box. If necessary, refer to the *RF300 Wall Box Installations Instructions*.

Both the *DSP320.2 User Guide* and the *RF300 Installation Instructions* can be found by scanning the QR code shown here or by visiting:

[meridian-audio.com/DSP3202](http://meridian-audio.com/DSP3202)



## 1. CONTENTS

Each DSP320.2 loudspeaker is supplied with the following components:

- Trim-frame.
- Grille.
- 3mm Allen Key.
- 4 x M5 guide screws for installing into rough-in box.
- 2 x grille extractor keys.

## 2. PREPARE FOR INSTALLATION

Remove the grille and trim-frame from the loudspeaker and put them to one side for use (if required) later on.

The weight of the loudspeaker and the method of installation mean that assistance from a second person is often beneficial when installing the loudspeaker.

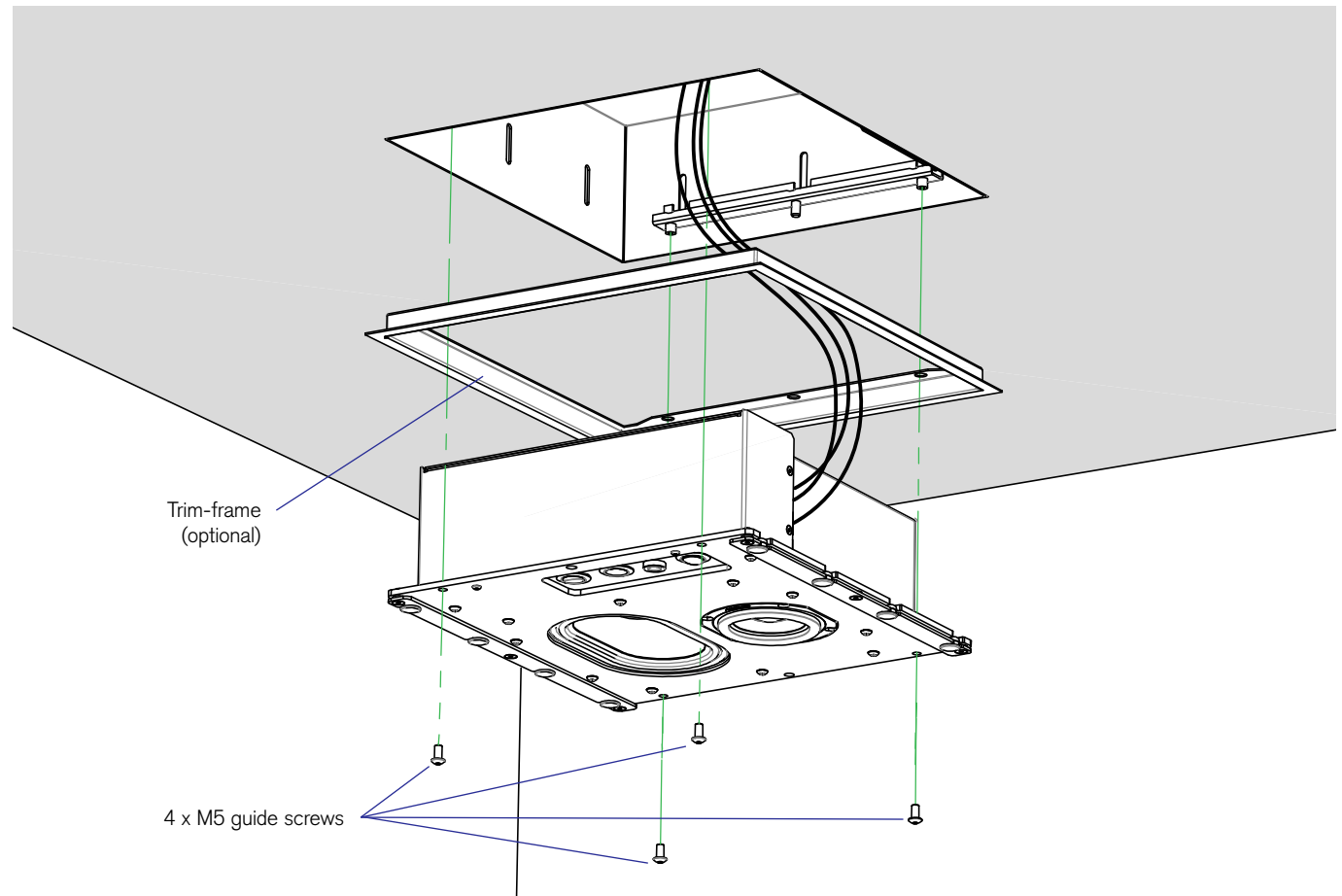

## 3. INSTALLATION

Make the following connections between the loudspeaker and the rough-in box:

- SpeakerLink input cable.
- SpeakerLink output cable (if used – see the *User Guide* for more information)
- Mains cable

Fit the loudspeaker into the rough-in box, being careful to avoid trapping the connecting cables.

Set the channel selector switch as appropriate – see the *User Guide* for further explanation.

Set the power switch to **On**.

Fit the grille if required.

## IMPORTANT SAFETY INSTRUCTIONS

- Read the instructions.
- Keep these instructions.
- Follow all instructions.
- Do not use this apparatus near water.
- Clean only with a dry cloth.
- Install only in accordance with the manufacturer's instructions.
- Refer all servicing to approved service personnel.

WARNING: TO REDUCE THE RISK OF FIRE OR ELECTRIC SHOCK, DO NOT EXPOSE THIS APPARATUS TO RAIN OR MOISTURE.

This apparatus has been designed with Class 1 construction and must be connected to a mains socket outlet with a protective earthing connection (the third grounding pin).

This apparatus uses a single-pole power switch. As a result it is not isolated from AC mains power when switched off at the front panel. The apparatus may be isolated from mains power either by unplugging the power connector from the rear of the unit, or by unplugging the connector at the opposing end of the power cord or cable from its supply outlet. As a result, either or both of these connectors should remain accessible.

## SAFETY WARNINGS

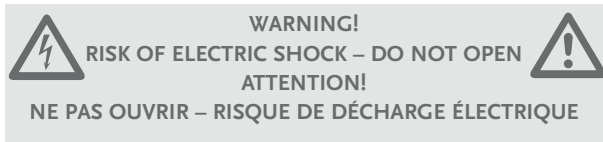

**Caution:** to reduce the risk of electric shock, do not remove cover. No user serviceable parts inside. Refer servicing to qualified service personnel.



The lightning flash with arrowhead symbol, within an equilateral triangle, is intended to alert the user to the presence of uninsulated "dangerous voltage" within the product's enclosure that may be of sufficient magnitude to constitute a risk of electric shock to persons.



The exclamation point within an equilateral triangle is intended to alert the user to the presence of important operating and maintenance (servicing) instructions in the literature accompanying the appliance.

## IP20 EQUIPMENT

### CLIMATE

The equipment has been designed for use in moderate climates and in domestic situations.

Only use at an altitude not exceeding 2000m.



## SAFETY WARNINGS

- Do not expose the unit to dripping or splashing.
- Do not place any object filled with liquid, such as a vase, on the unit.
- Do not place naked flame sources, such as lighted candles, on the unit.

## TO AVOID OVERHEATING

- Do not position the product in direct sunlight.
- Do not position the product near heat sources, such as a radiator.
- Leave at least 10cm around the product to ensure sufficient ventilation.

## RADIO INTERFERENCE

FCC Warning: This equipment generates and can radiate radio frequency energy and if not installed and used correctly in accordance with our instructions may cause interference to radio communications or radio and television reception. It has been type-tested and complies with the limits set out in Subpart J, Part 15 of FCC rules for a Class B computing device. These limits are intended to provide reasonable protection against such interference in home installations.



EEC: This product has been designed and type-tested to comply with the limits set out in EN55032:2015 and EN55024:2010 + A1:2015.

## SPECIFICATIONS

### PHYSICAL

Dimensions: 300mm x 300mm x 103mm (H x W x D)

Weight: 5kg

### POWER

500W max

This product is available factory pre-set in the following voltage options:

- 100V AC 50-60Hz
- 110-120V AC 50-60Hz
- 220-240V AC 50-60Hz

Meridian Audio reserves the right to amend product specifications at any time.

Copyright © 2020 Meridian Audio Ltd.

Part no: P88486

Designed and manufactured in the UK by Meridian Audio Ltd. Meridian Audio reserves the right to make changes and improvements to any of the products described in this document without prior notice.

## VISIT US ON THE WEB

[www.meridian-audio.com](http://www.meridian-audio.com)

